



SAFETY

OZONE

ENVIRONMENT

PROCESS

← Applications

- Thermal ozone destruct units are suitable for all types of processes where catalytic poisons are present

← Main characteristics

- The RB units include a heater, reaction chamber, suction fan, control system and are an energy-efficient solution



Off-gases containing trace levels of un-reacted ozone must be passed through a thermal or catalytic type vent ozone destruct unit before venting to the atmosphere.

MAIN FEATURES

- Very high ozone destruct efficiency
- Low power consumption
- Long service life
- Virtually maintenance-free

- Easy integration
- Compact dimensions
- High product integrity

OZONE DESTRUCT TECHNOLOGY

Exhaust gases from processes where ozone has been used invariably contain residual amounts of un-reacted ozone. Before this exhaust can be vented into the atmosphere, it is necessary to decompose the traces of ozone. In most countries it is prohibited to release even low-level concentrations into the atmosphere. There are various methods available to treat vent gas.

Two popular methods are thermal and catalytic destruction which are selected to match the process in question. The thermal destruct units raise the temperature of the off-gas to a level where the half-life of the ozone is reduced to milliseconds and in the catalytic units the ozone molecule decay rate is accelerated on the surface of the catalyst converting the ozone to oxygen.

HOW IT WORKS

The vent gases leaving the process are routed to the RB vent ozone destruct unit. In the reaction chamber the gases are heated-up to around 400°C which radically reduces the half-life of the ozone molecule and, consequently, accelerates the decomposition rate so that the ozone content in the gas stream leaving the VOD is well

below the recognised safety limits (< 0.1 ppm). In order to reduce the electrical requirement for heating the system incorporates a heat recuperation feature.

TECHNICAL DATA

RB™ Model	Mass Flow		Ozone Level		Operating Pressure	Electrical Rating
	Air kg/h	Oxygen kg/h	Inlet wt%	Outlet ppm		
RB-10	100	110	< 1.5	< 0.1	±0.1	6.7
RB-13	125	140	< 1.5	< 0.1	±0.1	7.7
RB-16	160	175	< 1.5	< 0.1	±0.1	9.2
RB-20	200	220	< 1.5	< 0.1	±0.1	10.7
RB-25	250	275	< 1.5	< 0.1	±0.1	12.7
RB-32	315	350	< 1.5	< 0.1	±0.1	15.7
RB-40	400	440	< 1.5	< 0.1	±0.1	18.7
RB-50	500	550	< 1.5	< 0.1	±0.1	22.7
RB-63	630	700	< 1.5	< 0.1	±0.1	27.7
RB-80	800	880	< 1.5	< 0.1	±0.1	38.5
RB-100	1000	1100	< 1.5	< 0.1	±0.1	46.5
RB-125	1250	1400	< 1.5	< 0.1	±0.1	57.5
RB-160	1600	1750	< 1.5	< 0.1	±0.1	72.5
RB-200	2000	2200	< 1.5	< 0.1	±0.1	91.0
RB-250	2500	2750	< 1.5	< 0.1	±0.1	115.0
RB-315	3150	3500	< 1.5	< 0.1	±0.1	150.0
RB-400	4000	4400	< 1.5	< 0.1	±0.1	180.0
RB-500	5500	5500	< 1.5	< 0.1	±0.1	230.0

► Standards

- Design standards: EN, IEC, ISO, SN
- Protection class: IP 42
- Conformity: CE
- Connection data: 3 x 400 V ±10%, 50 Hz

► Materials

- VOD: EN 1.4301/1.4306
- Skid: Galvanised mild steel
- Fan: Galvanised mild steel
- Insulation : Mineral wool
- Cover sheet: Galvanised mild steel

► Remote controls and alarms

- Enable REMOTE
- Unit running
- Temperature lower than max. alarm value
- Temperature higher than lower alarm value
- Over protection switch tripped
- All miniature circuit breakers are ON
- Unit ON/OFF

DIMENSIONS

RB™ Model	I x h w	Weight kg
	mm	
RB-10	4330 x 1740 x 800	720
RB-13	4330 x 1740 x 800	730
RB-16	4370 x 1840 x 900	1030
RB-20	4370 x 1840 x 900	1050
RB-25	4370 x 1840 x 900	1070
RB-32	4970 x 1915 x 1000	1250
RB-40	4970 x 1915 x 1000	1280
RB-50	5050 x 1915 x 1000	1600
RB-63	5050 x 1915 x 1000	1670
RB-80	5540 x 2180 x 1100	1780
RB-100	5540 x 2180 x 1100	1850
RB-125	6090 x 2355 x 1200	2700
RB-160	6090 x 2355 x 1200	2800
RB-200	6380 x 2605 x 1300	3100
RB-250	6380 x 2605 x 1300	3300
RB-315	6580 x 2855 x 1300	4000
RB-400	7180 x 2905 x 1400	4900
RB-500	7280 x 3105 x 1500	5800

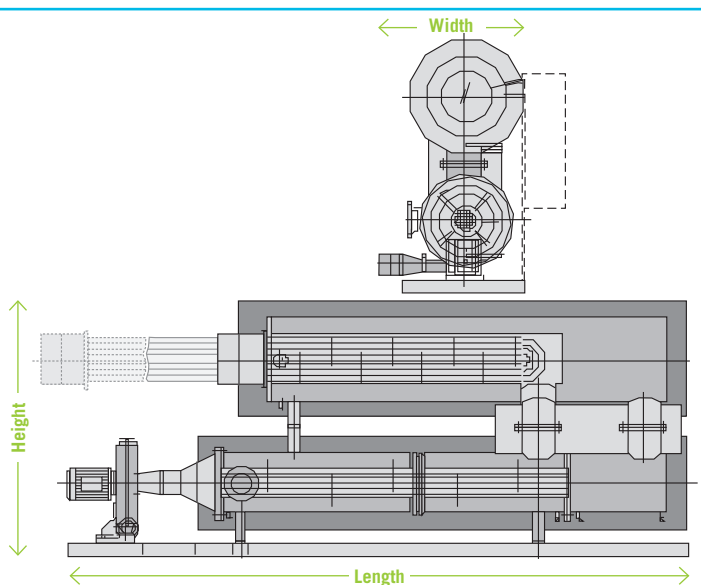

Contacts

www.DEGREMONT-TECHNOLOGIES.COM

Ozonía International Ozone	• info-ozoniaCH@degtec.com	• + 41 44 801 8511
Ozonía France	• info-ozoniaFR@degtec.com	• + 33 1 58 81 50 00
Ozonía North America	• info-ozonia@degtec.com	• + 1 201 676 2525
Ozonía Triogen UK	• info-triogen@degtec.com	• + 44 13 55 220 598
Ozonía Russia OOO	• info-ozoniaRU@degtec.com	• + 7 831 434 1628
Ozonía Korea	• info-ozoniaKR@degtec.com	• + 82 31 701 9036
Ozonía China	• info-china@degtec.com	• + 86 10 659 73 860
Ozonía Japan	• info-japan@degtec.com	• + 81 3 544 46 361

Your local distributor: